

THE NRCA ROOFING MANUAL CONSTRUCTION DETAIL C-1	COPING • 24 GA. STEEL • 22 GA. STEEL CLEAT • CONTINUOUS FRONT FACE CLEAT AND GASKETED BACK FACE FASTENER	ANSI/SPRI ES-1 TESTED RESISTANCE		UL-40 8/31/17
		OUTWARD 98 LBS./SQ. FT.	UPWARD 170 LBS./SQ. FT.	

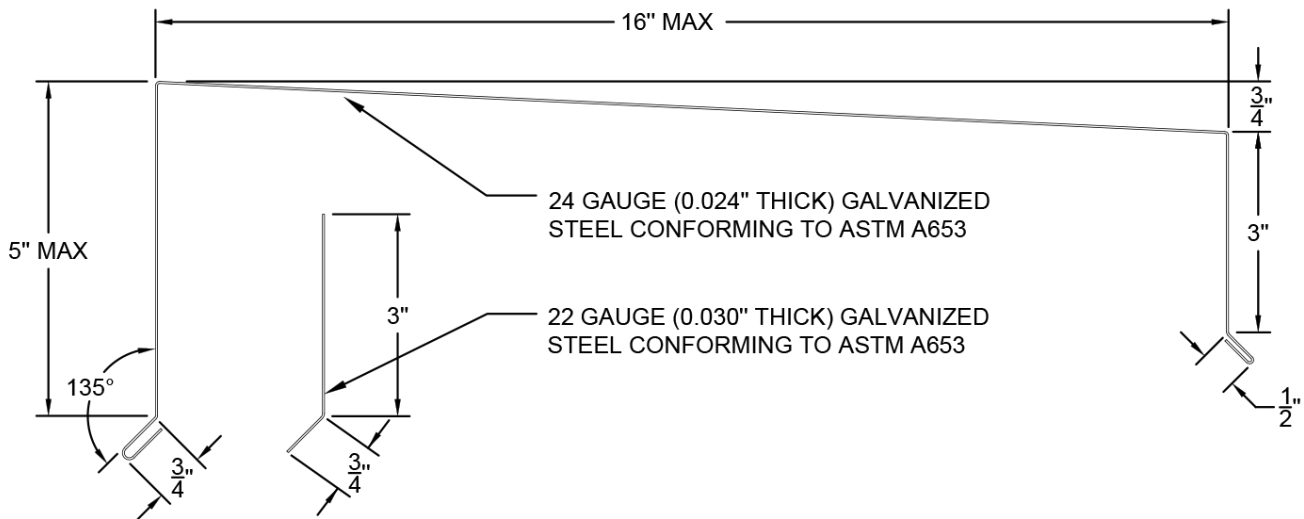

FABRICATION

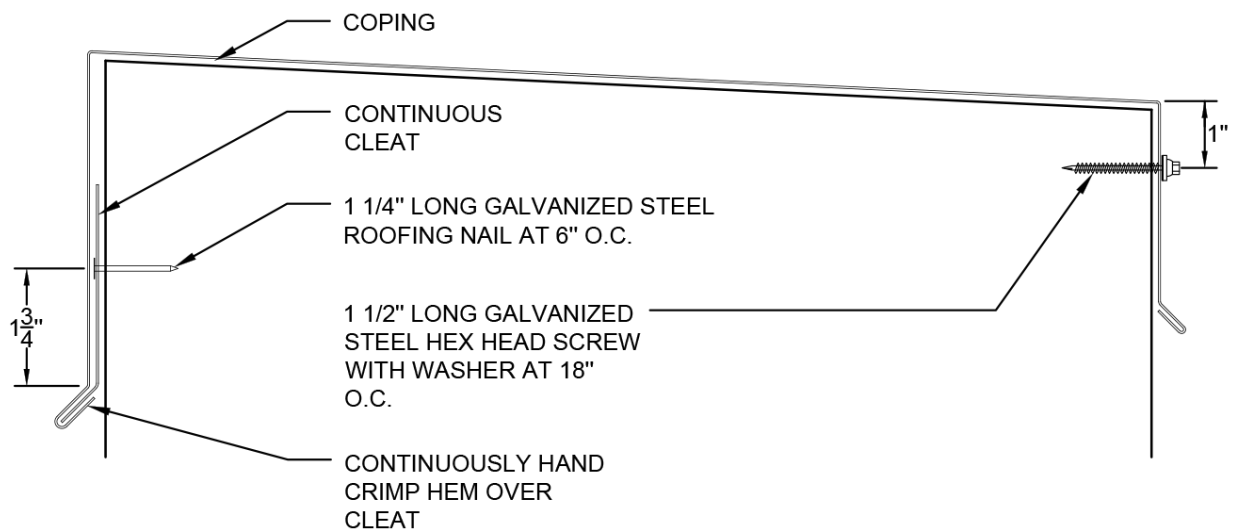

INSTALLATION

THE NRCA ROOFING MANUAL CONSTRUCTION DETAIL C-1	COPING <ul style="list-style-type: none"> • 0.040" ALUMINUM • 0.050" ALUMINUM CLEAT • CONTINUOUS FRONT FACE CLEAT AND GASKETED BACK FACE FASTENER 	ANSI/SPRI ES-1 TESTED RESISTANCE		UL-41 8/31/17
		OUTWARD 144 LBS./SQ. FT.	UPWARD 250 LBS./SQ. FT.	

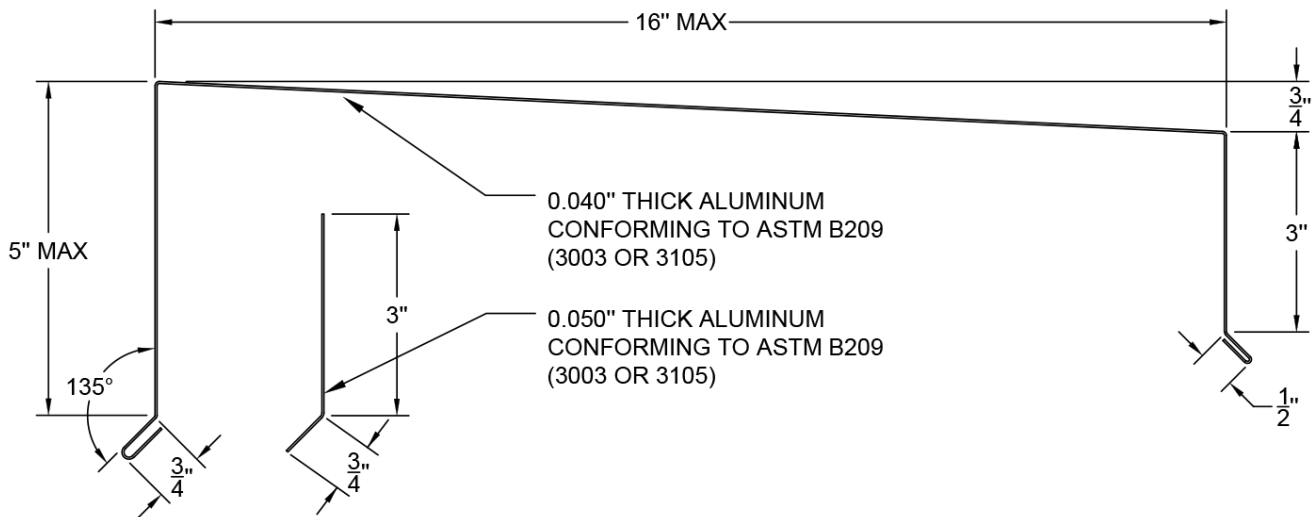

FABRICATION

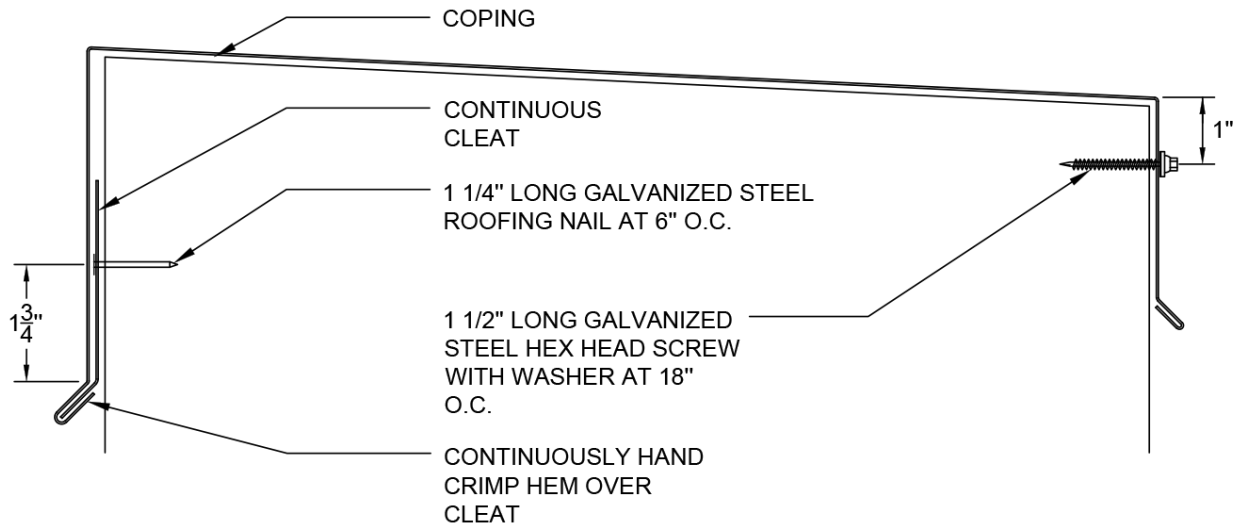

INSTALLATION