

<b>THE NRCA ROOFING MANUAL</b> CONSTRUCTION DETAIL C-6	<b>COPING WITH FLAT DRIP</b> <ul style="list-style-type: none"> <li>• 24 GA. STEEL</li> <li>• 22 GA. STEEL CLEAT</li> <li>• CONTINUOUS FRONT FACE CLEAT AND GASKETED BACK FACE FASTENER</li> </ul>	<b>ANSI/SPRI ES-1 TESTED RESISTANCE</b>		<b>UL-18</b>  10/30/15
		OUTWARD 95 LBS./SQ. FT.	UPWARD 160 LBS./SQ. FT.	

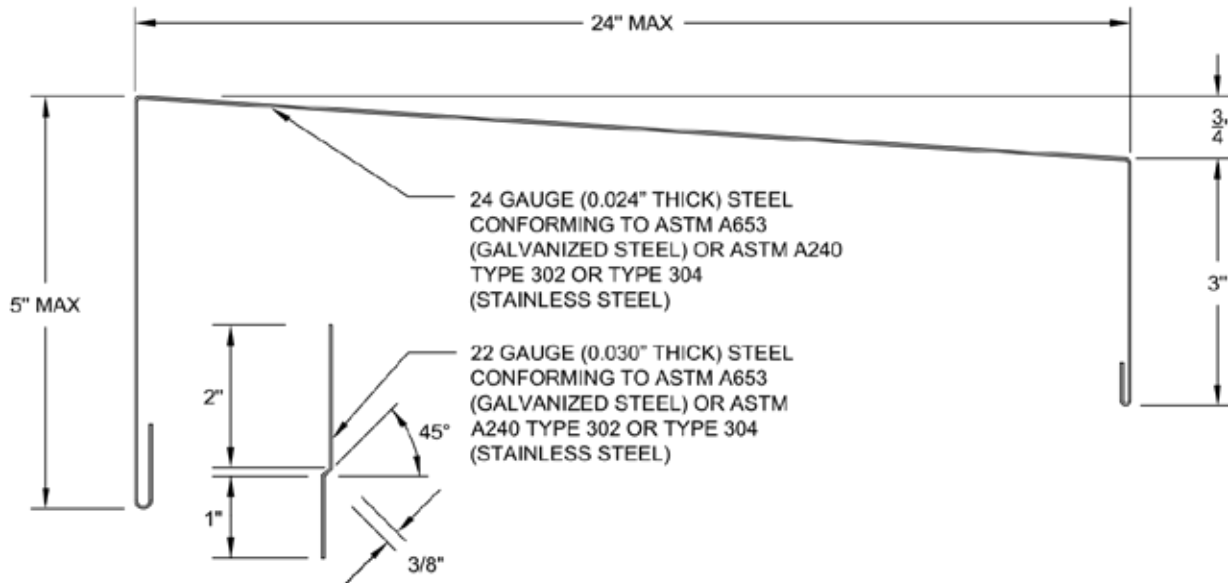

### FABRICATION

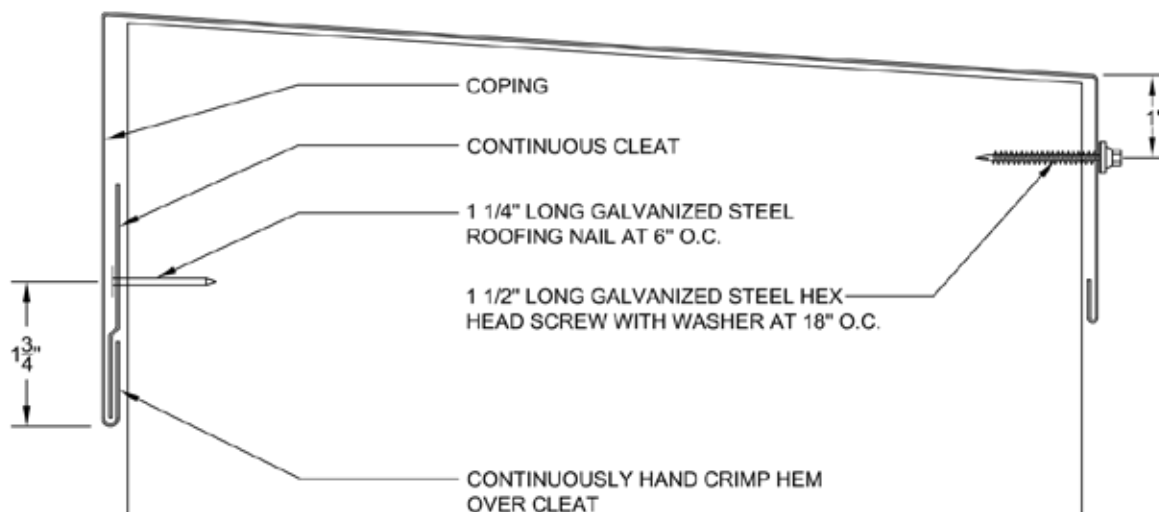

### INSTALLATION

<b>THE NRCA ROOFING MANUAL</b> CONSTRUCTION DETAIL C-7	<b>COPING WITH FLAT DRIP</b> • 24 GA. STEEL • 22 GA. STEEL CLEAT • CONTINUOUS FRONT FACE CLEAT AND GASKETED BACK FACE FASTENER	<b>ANSI/SPRI ES-1 TESTED RESISTANCE</b>		<b>UL-18A</b>  10/30/15
		OUTWARD 95 LBS./SQ. FT.	UPWARD 160 LBS./SQ. FT.	

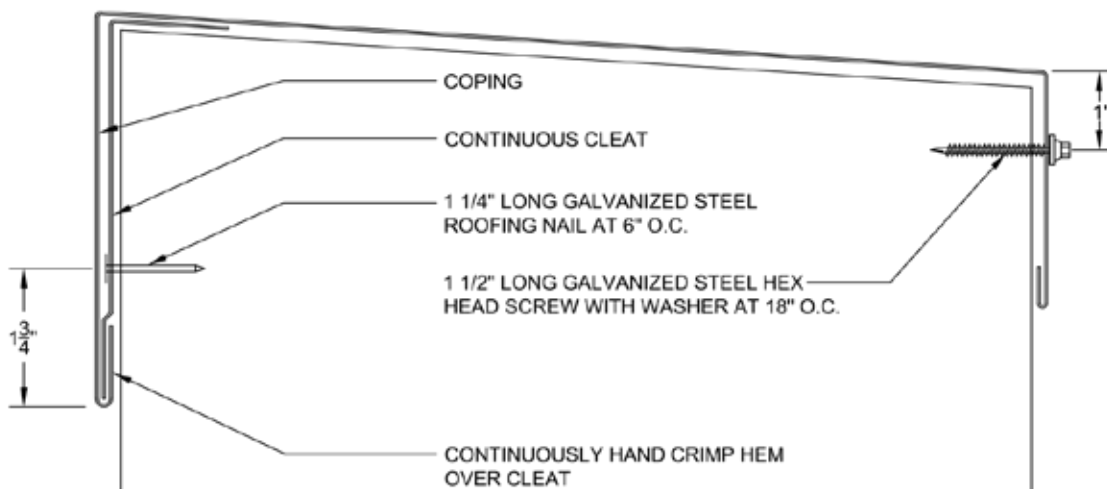
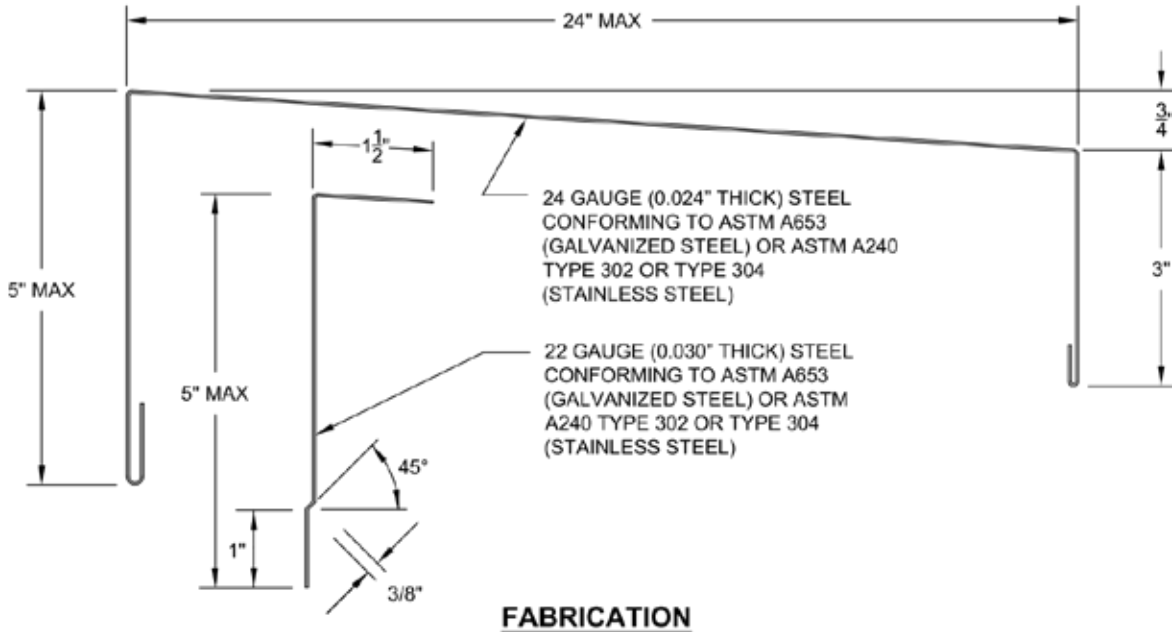

<b>THE NRCA ROOFING MANUAL</b> CONSTRUCTION DETAIL C-6	<b>COPING WITH FLAT DRIP</b> <ul style="list-style-type: none"> <li>• 0.050" ALUMINUM</li> <li>• 0.063" ALUMINUM CLEAT</li> <li>• CONTINUOUS FRONT FACE CLEAT AND GASKETED BACK FACE FASTENER</li> </ul>	<b>ANSI/SPRI ES-1 TESTED RESISTANCE</b>		<b>UL-19</b>  2/6/17
		OUTWARD 90 LBS./SQ. FT.	UPWARD 150 LBS./SQ. FT.	

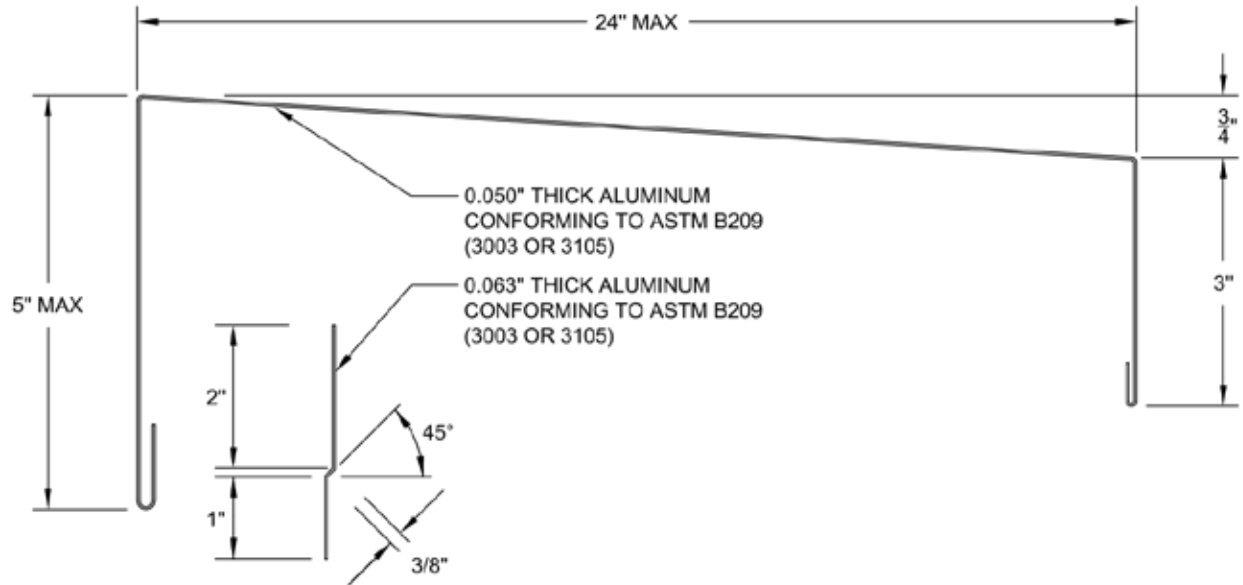

**FABRICATION**

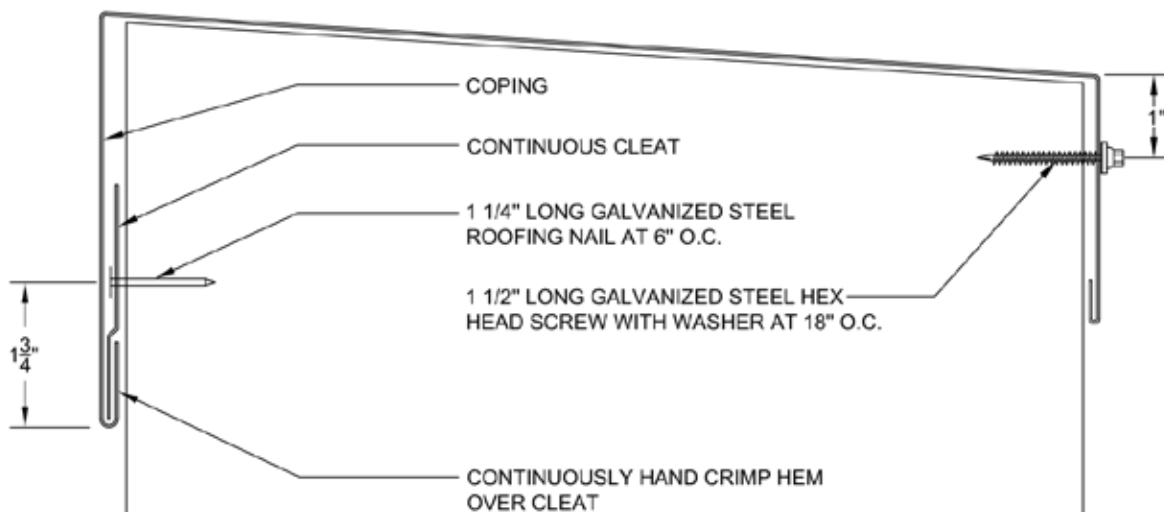

**INSTALLATION**

<b>THE NRCA ROOFING MANUAL</b> CONSTRUCTION DETAIL C-7	<b>COPING WITH FLAT DRIP</b> <ul style="list-style-type: none"> <li>• 0.050" ALUMINUM</li> <li>• 0.063" ALUMINUM CLEAT</li> <li>• CONTINUOUS FRONT FACE CLEAT AND GASKETED BACK FACE FASTENER</li> </ul>	<b>ANSI/SPRI ES-1 TESTED RESISTANCE</b>		<b>UL-19A</b>  2/6/17
		OUTWARD 90 LBS./SQ. FT.	UPWARD 150 LBS./SQ. FT.	

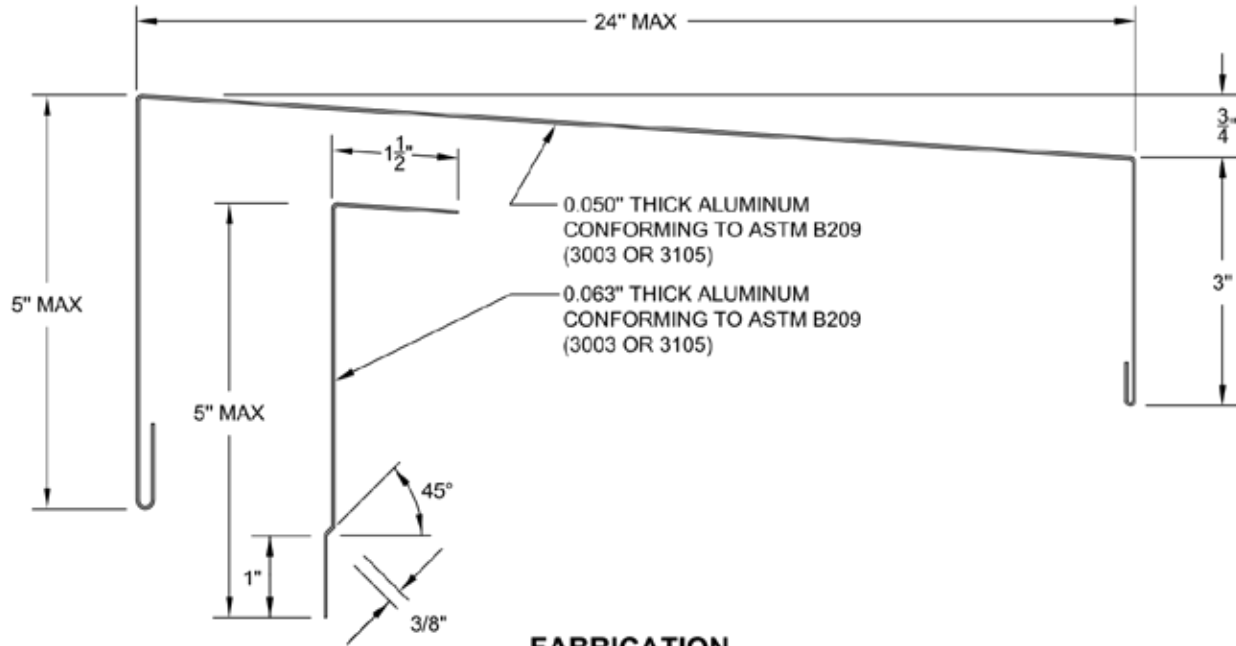

**FABRICATION**

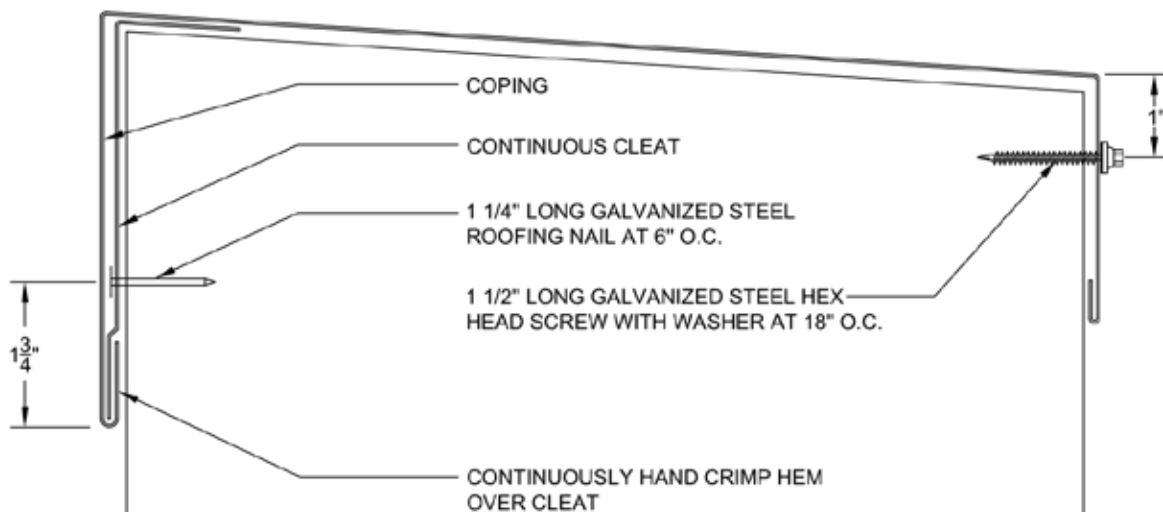

**INSTALLATION**